

#S7/97

PRICE \$5.95

QUALITY **FAST DELIVERY** **ECONOMY**



WHITE ...*performance beyond the ordinary*
DIAMOND

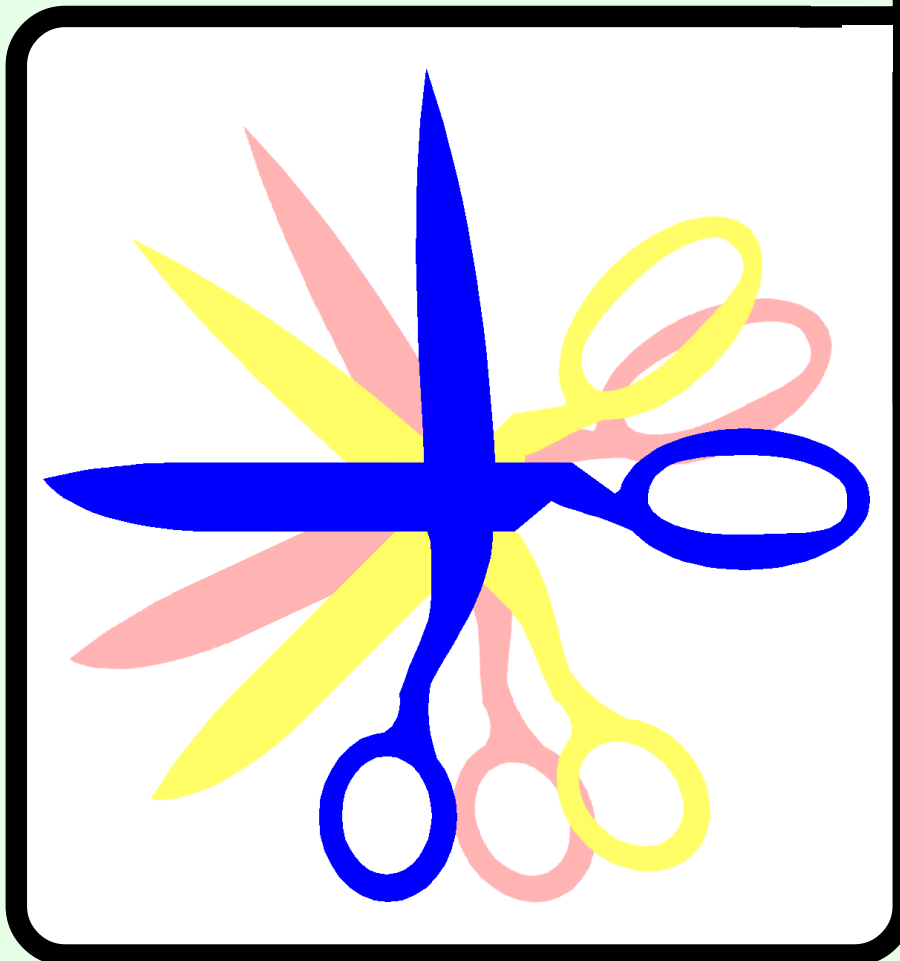

- **WISS**
- **MUNDIAL**
- **GOLD SEAL**
- **BELMONT**
- **FISKARS**
- **ACCESSORIES**

Your Cutting Supply Resource

**Diamond
Needle
Corp.**



**WHITE
DIAMOND**

G.P.O. 1355
159-163 WEST 25TH STREET
NEW YORK, NY 10001
E-mail: Diamond-Needle@worldnet.att.net



212-929-2277
CALL TOLL-FREE
1-800-221-5818



1-800-833-3363
(DOMESTIC)
212-242-8882
(INTERNATIONAL)

HAND MATES

IMPROVE PRODUCTIVITY

Hand~Mates™

SUPPORT GLOVES

Hundreds of Uses Including...
Sewing & Quilting, Craft & Hobby Work, Computer Use, Assembly Work, Food Processing...and more!



Hand~Mates™ Provide...
Massage / Heat/ Support
Relief from Nagging Aches and Pain

Should be used any time repetitive hand motion causes fatigue to hands or wrist.

Start your day by putting on Hand~Mates™ and your hands will feel more comfortable and relaxed than ever before!

Heat...

Naturally generated by the body, warmth is retained within the tightly knit fabric. This keeps muscles relaxed and stimulates circulation.

Support...

Just like what support hose do for legs...Hand~Mates™ comfortably reinforce the palm and wrist – leaving your fingers free to handle your work.

Massage...

The gentle “give and take” of the fabric keeps muscles free from fatigue and promotes better circulation...



Insert your ring and middle fingers together through the center hole.

Hand~Mates™ can be worn under protective or sport gloves.

Washable
88% Nylon / 12% Spandex

Hand~Mates



Size Guide

X-Large

Large

Medium

Small

Place palm here and measure across knuckles.

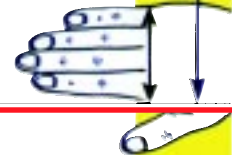

ECONOMICALLY PRICED

#HM-501 SMALL #HM-502 MEDIUM #HM-503 LARGE #HM-504 EXTRA LARGE

Diamond Needle Corp.

GPO BOX 1355 • 159 W 25 St. • New York, NY 10001
Phone: (212) 929-2277 • (800) 221-5818
FAX: (212) 242-8882 • (800) 833-3363



**WHITE
DIAMOND**

Through the support of our valued customers worldwide, we are pleased to introduce our new **Scissors & Shears** and **Accessories** catalog.

This catalog is an in-depth listing and illustration of cutting tools available from leading manufacturers. Our extensive lines are economically priced to meet your specific requirements at multiple quantity levels. We maintain a vast inventory to assure prompt delivery at all times.

This catalog's illustrations and descriptions help you find the right tools, new ideas and answers for many cutting applications. Because decisions are made dependent on quality information, we have devoted considerable efforts to make this useful information easier to access. We recognize the importance of your support. Please feel free to contact us anytime with your orders, inquiries and recommendations as to how we can improve our products and services. We never forget that we've got to earn your business all of the time.

GLOSSARY

Knife-Edge	The bottom blade is ground to a standard 20 degree bevel. The top blade bevel is increased from 30 degrees to 50 degrees. The easiest cut but sacrifices edge life.
Hot Drop-Forged	Construction process that provides sturdiness and lasting sharpness. Tempered and hardened scissors can be sharpened again and again.
Inlaid (Wiss)	Precision construction process that offers extraordinary edge properties for high performance and features the "Easy-set" pivot.
Scissors	The finger bows are identical.
Shears	The finger bows are NOT identical, or any scissor over 6" in length.
Compound Action	The insertion of gears or levers to mechanically multiply the cutting power of the shears.
Ice Tempered	A special hardening process to extend the life of the cutting edge.

QUICK-INDEX

PRODUCT/BRAND	PRODUCT	PAGE
HAND-MATES	Support Gloves	2
WISS	Scissors & Shears	4-6
	Specialty Shears & Snips	7-10
	Thread Clips	10
MUNDIAL	Scissors & Shears	11-12
	Specialty Shears & Snips	13-14
	Lightweight Scissors & Shears ..	15-16
WOLFF	Scissors Sharpener	17
GOLD SEAL	Thread Nippers	18-19
	Hones	19
	Scissors & Shears	20-21
BELMONT	Scissors & Shears	22-24
	Specialty Scissors & Snips	25-27
	Thread Nippers	27
FISKARS	Scissors, Shears, Snips, Cutters	28-29
CHAINEX	Mesh Gloves, Aprons	30-31
TOOLS	Tweezers, Seam Rippers, etc.	32
DIXON	Marking Crayons and Pencils	33

The WISS Quality Story

The name WISS has been synonymous with fine quality shears and scissors since 1848. This position of eminence is unparalleled in the industry and has been achieved by maintaining a standard of manufacturing excellence that has made WISS a household word in this country and throughout the world.

The manufacture of WISS shears and scissors begins with the finest quality cutlery steel and a knowledge of metallurgy achieved from years testing and analyzing these products at every stage of production.

The combination of this with the dedication and experience of skilled craftsmen, is responsible for the cutting edge superiority that has established WISS shears and scissors as the standard of excellence in the industry.

HEAVY DUTY INDUSTRIAL SHEARS

INLAID

Professional, Industrial/Tailor. Ideal for heavy-duty extensive, multiple layer cutting.



- Hot drop-forged, polished blades with black handle.
- Patented set-easy pivot, easy hand adjustment.

ITEM NO.	FULL LENGTH	CUT LENGTH
W20	10" - 260mm	4 3/4" - 121mm
W20LH	10" - 260mm	4 3/4" - 121mm
W22	12" - 311mm	6 1/8" - 155mm

HEAVY DUTY INDUSTRIAL SHEARS with CUSHION GRIP INLAID

Red **Cushion Grip** handle provides maximum comfort.

ERGONOMIC



- Hot drop-forged, polished blades.
- Patented set-easy pivot, easy hand adjustment.

ITEM NO.	FULL LENGTH	CUT LENGTH
W20P	10" - 260mm	4 3/4" - 121mm
W20LHP	10" - 260mm	4 3/4" - 121mm
W22P	12" - 311mm	6 1/8" - 155mm

HEAVY DUTY INDUSTRIAL SHEARS

INLAID

The cutting blade is ground to knife-edge for faster, cleaner, easier cutting of today's synthetic fibers.

KNIFE-EDGE



- Ideal for heavy-duty cutting, upholstery, carpet and fabric.
- Hot drop-forged, polished blades with black handles.
- Patented set-easy pivot, easy hand adjustment.

ITEM NO.	FULL LENGTH	CUT LENGTH
W1225	10" - 260mm	4 3/4" - 121mm
W1226	12" - 311mm	6 1/8" - 155mm

HEAVY DUTY HIGH LEVERAGE INDUSTRIAL SHEARS INLAID

The cutting blade is ground to knife-edge and the red **Cushion Grip Elongated** handle design allows extra leverage for cutting extra thick or tough upholstery, carpet and fabric.

KNIFE-EDGE

ERGONOMIC



- Hot drop-forged, polished blades.
- Patented set-easy pivot, easy hand adjustment.

ITEM NO.	FULL LENGTH	CUT LENGTH.
W1225HLSP	10" - 260mm	4 3/4" - 121mm

**UPHOLSTERY, CARPET, DRAPERY
& FABRIC SHEARS**

INLAID

Thicker, heavy duty blades cut through multiple layers and tough materials.



- Hot drop-forged, polished blades with black handle.
- Patented set-easy pivot, easy adjustment.

<u>ITEM NO.</u>	<u>FULL LENGTH</u>	<u>CUT LENGTH</u>
W20W	10" - 260mm	4 3/4" - 121mm
W22W	12" - 311mm	6 1/8" - 155mm

BENT TRIMMERS

INLAID

Professional pattern cutters. Specially designed with bent (off-set) handles. Ideal for cutting fabrics of all weights without lifting shears off of cutting board, or cutting into board or table.



- Hot drop-forged, nickel plated blades with black handle.
- Patented set-easy pivot, easy adjustment.

<u>ITEM NO.</u>	<u>FULL LENGTH</u>	<u>CUT LENGTH</u>
W27	7" - 182mm	3 1/8" - 79mm
W28	8" - 206mm	3 3/4" - 95mm
W29	9" - 100mm	4" - 100mm

**UPHOLSTERY, CARPET, DRAPERY
& FABRIC SHEARS with CUSHION GRIP**

INLAID

Red **Cushion Grip** handle provides maximum comfort. Thicker, heavy duty blades cut through multiple layers and tough materials.

ERGONOMIC



- Hot drop-forged, polished blades.
- Patented set-easy pivot, easy hand adjustment.

<u>ITEM NO.</u>	<u>FULL LENGTH</u>	<u>CUT LENGTH</u>
W20WP	10" - 260mm	4 3/4" - 121mm
W22WP	12" - 311mm	6 1/8" - 155mm

STRAIGHT TRIMMERS

INLAID

Professional, for industrial, household, utility chores. Truly, general purpose.



- Hot drop-forged, nickel plated blades with black handle.
- Patented set-easy pivot, easy adjustment.

<u>ITEM NO.</u>	<u>FULL LENGTH</u>	<u>CUT LENGTH</u>
W36	6" - 158mm	2 5/8" - 66mm
W37	7" - 182mm	3 1/8" - 79mm
W38	8" - 206mm	3 3/4" - 95mm
W39	9" - 235mm	4 3/8" - 112mm
W30	10" - 260mm	4 7/8" - 124mm

BENT TRIMMERS - SOLID STEEL

Professional **Dressmaker's**. These high carbon steel shears provide outstanding cutting ability and durability on fabric of all weights in the true Wiss tradition.



- Hot drop-forged, nickel plated, black handle.
- Easy pivot adjustment.

ITEM NO	FULL LENGTH.	CUT LENGTH
W426	6" - 160mm	2 5/8" - 68mm
W427	7" - 182mm	3 1/8" - 79mm
W428	8" - 206mm	3 3/4" - 95mm

STRAIGHT TRIMMERS - SOLID STEEL

Professional, general purpose high carbon solid steel shears for cutting fabric, twine, paper, binding and almost any other miscellaneous household cutting task.



- Hot drop-forged, nickel plated with black handle.
- Easy pivot hand adjustment.

ITEM NO.	FULL LENGTH	CUT LENGTH
W436	6" - 160mm	2 5/8" - 66mm
W437	7" - 182mm	3 1/8" - 79mm
W438	8" - 206mm	3 3/4" - 95mm

SEWING SCISSORS - SOLID STEEL

Excellent for trimming light materials, ripping seams and for general sewing or craft purposes.



- Hot drop-forged, fully nickel plated.
- One sharp and one blunt point with ring handle.

ITEM NO.	FULL LENGTH	CUT LENGTH
W715	5" - 134mm	2 1/4" - 57mm
W716	6" - 156mm	2 3/4" - 70mm

PINKING SHEARS - SOLID STEEL

Pinking shears play a double role, used to create attractive outer edges as well as their established function of finishing inside seams with ravel resistant zig-zag edge.



- Hot drop-forged, fine cutlery steel, nickel plated blades and black handle.
- Bearing pivot reduces friction and finger fatigue.
- Extra large teeth provide decorative finish.

ITEM NO.	FULL LENGTH	CUT LENGTH
WCB9	9" - 228mm	3 1/4" - 83mm
WAA	10" - 270mm	3 7/8" - 97mm

TAILOR'S POINT - SOLID STEEL

Professional model, extra sturdy, ideal for light tailoring task such as, material, darning, ripping, millinery.



- Hot drop-forged, nickel plated with black handle.
- Double sharp points with larger ring handle.

ITEM NO	FULL LENGTH	CUT LENGTH
W75L	5" - 130mm	2" - 51mm

SEWING & EMBROIDERY SCISSORS - SOLID STEEL

Very fine sharp points. Useful for fine accurate cuts and trimming threads

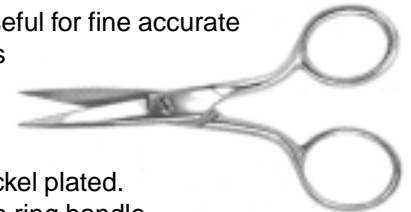

- Hot drop-forged, fully nickel plated.
- Double sharp points with ring handle.

ITEM NO.	FULL LENGTH	CUT LENGTH
W763 1/2	3 1/2" - 92mm	1 1/4" - 31mm
W764	4" - 105mm	1 3/8" - 35mm
W765	5" - 130mm	2" - 51mm
W766	6" - 156mm	2 1/2" - 64mm

SPECIALTY SHEARS & SNIPS

BELT & LEATHER SHEARS

INLAID

Specially designed, thick heavy-duty blades with one blade serrated and the other edged. Specifically constructed for leather and other tough and thick material cutting.



- Hot drop-forged, nickel plated with black handle.
- Patented set-easy pivot.

<u>ITEM NO.</u>	<u>FULL LENGTH</u>	<u>CUT LENGTH</u>
W8BLT	8" - 222mm	3" - 72mm

RUG SHEARS for HOOK & CANDLEWICK RUGS - SOLID STEEL

Specially designed with elongated shank and offset handle to get closer to level carpet surface.



- Hot drop-forged, nickel plated, black handle.
- Easy pivot adjustment.

<u>ITEM NO.</u>	<u>FULL LENGTH</u>	<u>CUT LENGTH</u>
WRS1	8" - 204mm	2 3/4" - 70mm

INDUSTRIAL UTILITY SHEARS

INLAID

Specially designed with elongated shank for maximum cutting leverage. Used extensively in poultry processing as well as in auto, marine, upholstery, florist, etc.



- Hot drop-forged, high carbon steel, nickel plated commercial finish.
- Patented set-easy pivot.

<u>ITEM NO.</u>	<u>FULL LENGTH</u>	<u>CUT LENGTH</u>
W1DS	8" - 216mm	3" - 76mm

LARGE RING INDUSTRIAL SHEARS

INLAID

Specially designed with elongated shank for maximum cutting leverage and **new enlarged lower ring handle** for added comfort. Also available with cushion grip and safety points.

ERGONOMIC



- Hot drop-forged, high carbon steel, commercial finish.
- Patented set-easy pivot.

<u>ITEM NO.</u>	<u>FULL LENGTH</u>	<u>CUT LENGTH</u>
W1DSLRL	9.25" - 235mm	3" - 76mm
W1DSLRLP (Plastisol Grips)		
W1DSLRLSP (Safety Points)		
W1DSLRLSPP (Plastisol Grips/Safety Points)		

HIGH LEVERAGE SHEARS - SOLID STEEL

Constructed with heavy-duty blades and elongated shank. Provides **maximum leverage** and ease of cutting. Extensively used for florist wire cutting as well as extra thick or tough materials.

HIGH LEVERAGE



- Nickel plated blades with black handle.
- Hot drop-forged, solid steel.
- Serrated blades for firm grip of material.

ITEM NO.	FULL LENGTH.	CUT LENGTH
W2DA	8" - 210mm	2 1/4" - 57mm

ELECTRICIAN'S SCISSORS - SOLID STEEL

Ideal for wire splicing, cutting insulation, stripping insulation and cutting harness ties. Perfect tool for any maintenance shop.



- Hot drop-forged, fully nickel plated.
- Scraper and file on back edge of blades.

ITEM NO.	FULL LENGTH	CUT LENGTH
W175E	5" - 133mm	1 7/8" - 48mm

SNIPS FOR CUTTING KEVLAR

Special heat treated high carbon solid steel. Deeper serration on one blade provides prolonged life when cutting Kevlar or other tough composite materials.

HIGH LEVERAGE



- Black oxide industrial finish.
- Hot drop-forged, high grade carbon steel.
- Will cut Kelvar and Spectra.

ITEM NO.	FULL LENGTH	CUT LENGTH
WKV2	8" - 210mm	2" - 51mm

POCKET SCISSORS - SOLID STEEL

Two blunt rounded ends prevent points from tearing or ripping. Heavy-duty flat pattern and ring handle makes them a convenient easy to use tool.



- Hot drop-forged, fully nickel plated.

ITEM NO.	FULL LENGTH	CUT LENGTH
W064	4" - 108mm	1 3/4" - 44mm
W065	5" - 133mm	2 1/4" - 58mm
W166	6" - 158mm	2 3/4" - 70mm
W166L (large ring handle)	6" - 165mm	2 3/4" - 70mm

METAL-WIZZ, MULTI PURPOSE SNIPS

Cuts curves, straight or any combination. Designed for craftsmen. Ideal for cutting lighter gauge metal, screening, shingles, carpet, etc.

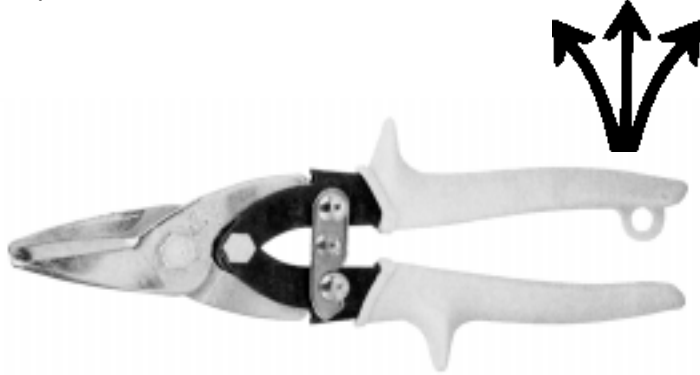

- Compound spring action for effortless cutting.
- Serrated jaw, non-slip cushion grips.

ITEM NO.	FULL LENGTH	CUT LENGTH
WMPC3	9" - 229mm	1 3/8" - 35mm

METALMASTER COMPOUND ACTION SNIPS

The jaws are made of extra tough, wear resistant molybdenum steel. Advanced technological cutting tool, ideal for industrial workers, maintenance specialists and professional metal workers. A versatile tool that will cut with half the effort required of conventional snips and will handle even the most difficult jobs.



- Non-slip serrated jaw allows for compound lever action.
- Compound spring-action for fast, effortless cutting.
- Handle of high tensile strength alloy.
- Handy hang-up hole
- Non-slip, textured grips and safety latch.

ITEM NO	FULL LENGTH.	CUT LENGTH
WM1R (LEFT CUT)	9 3/4" - 248mm	1 3/8" - 35mm
WM2R (RIGHT CUT)	9 3/4" - 248mm	1 3/8" - 35mm
WM3R (STRAIGHT CUT)	9 3/4" - 248mm	1 3/8" - 35mm

STRAIGHT PATTERN, SOLID STEEL TINNER'S SNIPS

Traditional tools of sheet metal trades, and craftsmen. Ideal for straight cutting and/or wide curves. Handyman's tool.



- Cushion handle for comfort and grip.

ITEM NO.	FULL LENGTH	CUT LENGTH
WA13	7" - 178mm	1 3/4" - 44mm
WA12	8" - 209mm	2" - 51mm
WA11	9" - 248mm	2 1/4" - 57mm
WA10	11" - 279mm	2 1/2" - 63mm
WA9	12" - 317mm	3" - 76mm

MULTIMASTER/MULTIPURPOSE SNIP

Anything that goes into the powerful jaws of this multimaster, isn't coming out in one piece. Great for making long, fast cuts in several types of material, including: paper, plastic, sheet metal, aluminum, vinyl siding, screening and many more.

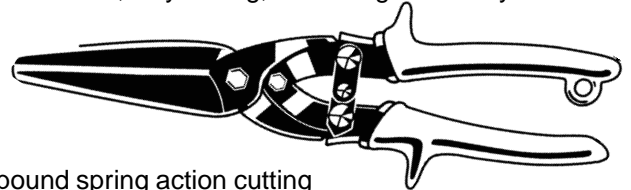

- Compound spring action cutting
- Non-slip serrated jaws, non-slip textured grips
- Cuts up to 20 gauge steel

ITEM NO.	FULL LENGTH	CUT LENGTH
WM300	13 1/2" - 343mm	3" - 76mm

INDUSTRIAL TRIMMING, GRAPE THINNING & ORCHID SNIPS/SOLID STEEL

Extensively used as industrial trimmers. They are ideal for pattern cutting. The short blades and coil spring handle provide control in close accurate cutting or trimming.



- Hot drop-forged, solid steel.
- Heavy pattern with adjustable nut.

ITEM NO.	FULL LENGTH	CUT LENGTH
WC4AS	8" - 204mm	2 1/4" - 57mm

(straight blades)

KITCHEN SHEARS - STAINLESS STEEL

Serves many purposes. Cuts variety of meats, fish, poultry; unscrews caps, cuts cord, cardboard, wire screening. It's an ideal all-purpose tool for home or workshop.



- Hot drop-forged, stainless steel
- One blade serrated
- Red baked enamel handle

ITEM NO	FULL LENGTH.	CUT LENGTH
WKSR	8" - 204mm	2 5/8" - 66mm

QUICK-CLIP SPEED CUTTERS

Stainless steel replaceable blades in ABS plastic, has high impact characteristics.

Contoured design ensures comfort. Quickly cut loose threads and ends of fabric.



- Self-opening spring action.

ITEM NO	FULL LENGTH	CUT LENGTH
W1570 (Sharp)	4 3/4" - 121mm	1" - 26mm
W1571 (Blunt)	4 3/4" - 121mm	1" - 26mm

REPLACEMENT PARTS - REPAIR KITS for W1570 & W1571

- W9317** Repair kit for W1570 (1 pr. of sharp blades, 4 blade screws, 1 spring, 1 stop screw)
- W9318** Repair kit for W1571 (1 pr. of blunt blades, 4 blade screws, 1 spring, 1 stop screw)
- W9328** Repair kit for W1570 (10 replacement sharp blades, 40 blade screws)
- W9329** Contents for W1571 (10 replacement blunt blades, 40 blade screws)

INDUSTRIAL THREAD CLIPS - SOLID STEEL

Solid steel, self-opening spring action assures fast effortless cutting. Pivot assembly with Teflon washer allows for adjustments. Fully nickel plated. Quickly cuts loose threads. For industrial use.



ITEM NO.	FULL LENGTH	CUT LENGTH
WTC1 (Sharp)	4 3/4" - 121mm	1 1/8" - 28mm
WTC5 (Blunt)	4 3/4" - 117mm	1" - 26mm

REPLACEMENT PARTS - REPAIR KITS FOR WTC1 & WTC5

WP1194 Contents for WTC1 & WTC5 (1 each, screw, nut, spring, stop screw)

INDUSTRIAL THREAD CLIPS - STAINLESS STEEL

Computer engineered ICE TEMPERED stainless steel, self-opening spring, delrin washer at pivot. 50% lighter than all steel.

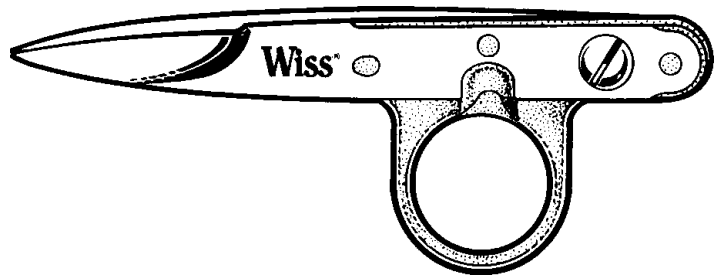

ITEM NO.	FULL LENGTH	CUT LENGTH
WTN1 (Sharp)	4 1/2" - 118mm	1 1/4" - 31mm
WTN5 (Blunt)	4 1/2" - 114mm	1 1/4" - 31mm



MUNDIAL



Mundial Four Aces, was established in Porto Alegre, Brazil in 1932. It was founded by cutlery craftsmen from the Solingen area of Germany.

An efficient combination of the latest technology, quality control and complete integration allows Mundial to manufacture quality scissors and shears to meet demanding industrial needs. Quality and economy in each tool.

INDUSTRIAL FORGED SHEARS - SOLID STEEL

Professional knife-edge, industrial/tailor. Ideal for cutting multiple layers with maximum ergonomic control.



- Hot drop-forged, nickel plated blades and black handles.
- Stay-set pivot assembly.

ITEM NO.	FULL LENGTH	CUT LENGTH
M420-10	10" - 254mm	4 7/8" - 124mm
M420-10LH (LEFT HAND)	10" - 254mm	4 7/8" - 124mm
M422-12	12" - 305mm	6 1/8" - 156mm

HEAVY DUTY INDUSTRIAL FORGED SHEARS - SOLID STEEL

Professional knife-edge, with heavier and wider blades, European style with **handle rest**. Designed for cutting upholstery, carpet, drapery and multiple layer fabrics.



- Hot drop-forged, nickel plated with black handle.
- Stay-set pivot assembly.

ITEM NO	FULL LENGTH	CUT LENGTH
M429-9	9" - 229mm	4 1/8" - 105mm
M420W	10" - 254mm	4 7/8" - 124mm
M422W	12" - 305mm	6 1/8" - 156mm

INDUSTRIAL FORGED UTILITY SHEARS SOLID STEEL

Professional knife-edge, elongated shank provides high leverage cutting ability. Used extensively in upholstery, auto/marine and more difficult cutting tasks.



- Hot drop-forged, nickel plated with black handle.
- Stay-set pivot assembly.

ITEM NO.	FULL LENGTH	CUT LENGTH
M456-8	8" - 203mm	3" - 76mm

BENT TRIMMERS - SOLID STEEL

Professional knife-edge, dressmaker shears for extensive cutting tasks. Ideal for cutting fabrics of all weights. A serrated blade is ideal for cutting fine synthetic fabric/material.



- Hot drop-forged.
- Adjustable bolt/nut pivot assembly.
- 455 series is nickel plated with black handle.
- 454 series is nickel plated with red handle

ITEM NO.	FULL LENGTH	CUT LENGTH
M455-6	6" - 152mm	2 5/8" - 67mm
M455-7	7" - 178mm	3 1/8" - 79mm
M455-8	8" - 203mm	3 5/8" - 92mm
M455-8LH (LEFT HAND)	8" - 203mm	3 5/8" - 92mm
M454-8 (SERRATED)	8" - 203mm	3 5/8" - 92mm
M406-7 (CHROME)	7" - 178mm	3 1/8" - 79mm
M406-8 (CHROME)	8" - 203mm	3 5/8" - 92mm
M406-8LH (CHROME)	8" - 203mm	3 5/8" - 92mm

Diamond Needle Corp.

GPO BOX 1355 • 159 W 25 St. • New York, NY 10001
Phone: (212) 929-2277 • (800) 221-5818
FAX: (212) 242-8882 • (800) 833-3363





MUNDIAL



STRAIGHT TRIMMERS - SOLID STEEL

Professional, knife-edge. For general utility purposes, industrial, household, etc., for light pattern cutting.



- Hot drop-forged, nickel plated with black handle.
- Adjustable bolt/nut pivot assembly.

ITEM NO	FULL LENGTH	CUT LENGTH
M355-6	6" - 152mm	2 5/8" - 67mm
M355-7	7" - 178mm	3 1/8" - 79mm
M355-8	8" - 203mm	3 5/8" - 92mm

PINKING SHEARS - SOLID STEEL

Professional, for use in creating attractive outer edges and finishing seams with ravel resistant zig-zag edge.

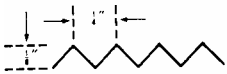

- Hot drop-forged, nickel plated, black handle.
- Bearing pivot - reduces friction and hand fatigue.
- Extra large teeth.

ITEM NO	FULL LENGTH.	CUT LENGTH
M407	7 1/2" - 191mm	2 7/8" - 73mm
M407LH	7 1/2" - 191mm	2 7/8" - 73mm
M409B	9" - 229mm	3 1/2" - 89mm
M410BAA	10" - 254mm	4" - 102mm

SEWING SCISSORS - SOLID STEEL

Professional, excellent for light to medium snipping and cutting. A general purpose tool for sewing and craft projects. Has one rounded and one sharp blade, ring handle and fully chrome plated.



- Hot drop-forged, fully chrome plated.
- Adjustable screw pivot assembly.

ITEM NO.	FULL LENGTH	CUT LENGTH
M202-5	5" - 127mm	2 1/4" - 57mm
M202-6	6" - 152mm	2 5/8" - 67mm

EMBROIDERY SCISSORS - SOLID STEEL

Professional, double sharp points and finely tapered blades make these scissors ideal for intricate detail work.



- Hot drop-forged, fully chrome plated, ring handle.
- Adjustable screw pivot assembly.

ITEM NO	FULL LENGTH	CUT LENGTH.
M102-3 1/2	3 1/2" - 89mm	1 1/4" - 32mm
M102-4	4" - 102mm	1 1/2" - 38mm
M102-5	5" - 127mm	2" - 51mm
M102-6	6" - 152mm	2 5/8" - 67mm

Diamond Needle Corp.

GPO BOX 1355 • 159 W 25 St. • New York, NY 10001
 Phone: (212) 929-2277 • (800) 221-5818
 FAX: (212) 242-8882 • (800) 833-3363



WHITE DIAMOND



MUNDIAL



SPECIALTY SCISSORS & SNIPS

THREAD CLIPS-SOLID STEEL

Self opening, knife-edge and fully chromed. Trims loose threads, ends of fabric, narrow ribbon, etc.

- Hot drop forged, sharp points.

ITEM NO	FULL LENGTH	CUT LENGTH
M301C	4 1/2" - 114mm	1" - 26mm



TAILOR POINT - SOLID STEEL

Professional model, extra sturdy blades with ring handle. For light tailoring tasks.

- Hot drop-forged, nickel plated with black handle.
- Adjustable screw pivot assembly.

ITEM NO	FULL LENGTH	CUT LENGTH
M275-5	5" - 127mm	2" - 51mm



BUTTONHOLE SCISSORS - SOLID STEEL

Adjustable screw sets the length of cut. Specifically designed for cutting precision button holes.

- Hot drop forged, fully chrome plated, ring handle.
- Adjustable screw pivot assembly.

ITEM NO.	FULL LENGTH	CUT LENGTH
M252	4 1/2" - 114mm	adjustable



SPECIALTY EMBROIDERY SCISSORS - SOLID STEEL

Finely tapered curved short blades with extra sharp points. Ideal for intricate work. Often called scherenschnitte or turmspitze or cuticle.

- Hot drop forged, fully chrome plated.
- Adjustable screw pivot assembly.

ITEM NO.	FULL LENGTH	CUT LENGTH
M701	3 1/2" - 89mm	7/8" - 22mm
M705	3 1/2" - 89mm	7/8" - 22mm

(705 HAS EXTRA NARROW BLADES)



APPLIQUE SCISSORS - SOLID STEEL

For trimming applique. Pelican bill, **offset blades**, ring handle.

- Hot drop-forged, fully chrome plated.
- Adjustable screw pivot assembly.

ITEM NO	FULL LENGTH	CUT LENGTH
M585	6" - 152mm	1 3/8" - 35mm



Diamond Needle Corp.

GPO BOX 1355 • 159 W 25 St. • New York, NY 10001
 Phone: (212) 929-2277 • (800) 221-5818
 FAX: (212) 242-8882 • (800) 833-3363





MUNDIAL



SPECIALTY SCISSORS & SNIPS

POCKET SCISSORS - SOLID STEEL

Blunt safety points, handy, just throw'em in your pocket.

- Hot drop-forged, fully chrome plated.
- Adjustable screw pivot assembly.

ITEM NO	FULL LENGTH	CUT LENGTH
M520-4	4" - 102mm	1 3/4" - 44mm



NOSE & EAR SCISSORS - SOLID STEEL

Safety rounded blunt points. Curved blades, ring handle, fully chromed, hot drop-forged.

- Adjustable screw pivot assembly.

ITEM NO.	FULL LENGTH	CUT LENGTH
M941	4" - 102mm	1 1/2" - 38mm



MUSTACHE SCISSORS - SOLID STEEL

Finely tapered blades for detailed trimming. Hot drop-forged, fully chromed, ring handle.

- Adjustable screw pivot assembly.

ITEM NO.	FULL LENGTH	CUT LENGTH
M944	4" - 102mm	1 1/2" - 38mm



NAIL SCISSORS - SOLID STEEL

Heavy pattern, curved blades, ideal for embroidery work. Hot drop-forged, fully chromed, ring handle.

- Adjustable screw pivot assembly.

ITEM NO.	FULL LENGTH	CUT LENGTH
M704	4" - 102mm	1 1/2" - 38mm



KITCHEN/POULTRY SHEARS

Poultry, fowl shears. Hot drop-forged, fully chrome plated

- Barrel spring-action (cuts poultry/fowl bones).

ITEM NO	FULL LENGTH	CUT LENGTH
M715	10 1/2" - 267mm	3" - 76mm



STAINLESS (Lightweight)

An indispensable tool. Shears, bottle opener, screwdriver, and jar cap gripper. All-purpose, with take-apart blades for easy thorough cleaning. They cut almost anything.

ITEM NO	FULL LENGTH	CUT LENGTH
M666	8" - 203mm	2" - 51mm



Diamond Needle Corp.

GPO BOX 1355 • 159 W 25 St. • New York, NY 10001
 Phone: (212) 929-2277 • (800) 221-5818
 FAX: (212) 242-8882 • (800) 833-3363



NOT RESPONSIBLE FOR TYPOGRAPHICAL ERRORS.



MUNDIAL



CUSHION SOFT STAINLESS LIGHTWEIGHT SHEARS

ERGONOMIC & AMBIDEXTROUS

Ideal for heavy use, and for people experiencing weakness in the hand.

NEW!

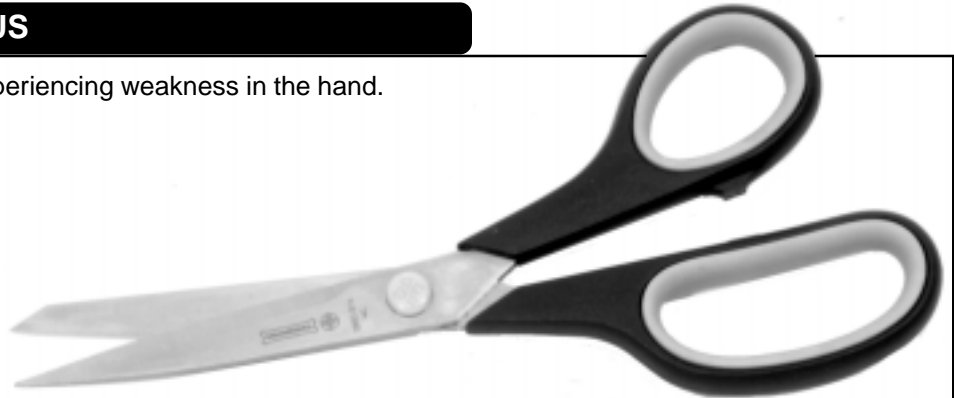

Knife-edge, adjustable pivot assembly.

Enlarged finger bows and soft-touch inserts for comfortable non-slip grip. Micro-serrated blade (except Pinking Shears) provides maximum control in cutting even the most delicate, silky fabrics.

ITEM NO.	DESCRIPTION	FULL LENGTH	CUT LENGTH
M1860-1	Dressmaker	8" - 203mm	3 5/8" - 92mm
M1890-1	Professional Dressmaker	9" - 229mm	4 1/8" - 105mm
M1865-1	Pinking Shears	7 1/2" - 191mm	2 7/8" - 73mm

PREMIUM STAINLESS LIGHTWEIGHT SCISSORS & SHEARS

Cutlery quality stainless blades with comfortable matte black polypropylene handles to prevent slippage. Adjustable pivot assembly protected by red button. Knife-edge. Resharpenable.

DRESSMAKER SHEARS

ITEM NO.	FULL LENGTH	CUT LENGTH
M660	8" - 203mm	3 5/8" - 92mm
M661LH (LEFT HAND)	8" - 203mm	3 5/8" - 92mm
M690	9" - 229mm	4 1/8" - 105mm



PINKING SHEARS

• Ravel resistant zig-zag edge cut.

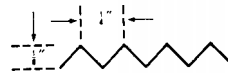

ITEM NO.	FULL LENGTH	CUT LENGTH
M665	7 1/2" - 191mm	2 7/8" - 73mm



Diamond Needle Corp.

GPO BOX 1355 • 159 W 25 St. • New York, NY 10001
Phone: (212) 929-2277 • (800) 221-5818
FAX: (212) 242-8882 • (800) 833-3363





MUNDIAL



PREMIUM STAINLESS LIGHTWEIGHT SCISSORS & SHEARS

Cutlery quality stainless blades with comfortable matte black polypropylene handles to prevent slippage. Adjustable pivot assembly protected by red button. Knife-edge. Resharpenable.

STRAIGHT TRIMMERS

For light duty cutting and trimming.

ITEM NO.	FULL LENGTH	CUT LENGTH
M662	7" - 178mm	3 1/4" - 83mm



EMBROIDERY SCISSORS

Double sharp points.

ITEM NO.	FULL LENGTH	CUT LENGTH
M668	4 1/2" - 114mm	1 3/8" - 35mm
M664	5 1/2" - 140mm	1 7/8" - 48mm



BARBER/LINGERIE SHEARS

Micro serrated bottom blade. Ideal for cutting fine hair, fabrics and threads.

ITEM NO.	FULL LENGTH	CUT LENGTH
M663	7 1/2" - 191mm	2 3/4" - 70mm



POCKET/SAFETY POINT SCISSORS

Safety blunt points, ring handle. Handy and durable.

ITEM NO.	FULL LENGTH	CUT LENGTH
M667	5" - 127mm	1 1/2" - 38mm



THREAD CLIP

Premium contoured plastic handle with high impact characteristics. Lightweight.

- Spring return action
- Comfort molded grip

ITEM NO.	FULL LENGTH	CUT LENGTH
M601	4 3/4" - 121mm	1 1/4" - 32mm



Diamond Needle Corp.

GPO BOX 1355 • 159 W 25 St. • New York, NY 10001
Phone: (212) 929-2277 • (800) 221-5818
FAX: (212) 242-8882 • (800) 833-3363



WHITE DIAMOND

WOLFF *Twice As Sharp* **PROFESSIONAL SCISSORS/SHEARS SHARPENER**

TWICE AS SHARP is a USA manufactured sharpener guaranteed to give you professional sharpening and reconditioning results. This no-maintenance machine comes packed with a 1/5 HP condenser run motor, precision double sealed ball bearings. The free moving arms have double sealed Rulon bearings, meaning no maintenance required.

KEY FEATURES

- Full 1/2" wide sharpening wheel, 100 grit fine grain friable aluminum oxide.
- Grinding length is 14" without reclamping, and 28" with extra long arms.
- Holds all types and sizes, including pinking shears.
- Angles are fully adjustable from 0- 57 degrees.
- Comes complete with safety glass, breathing mask, lubricant, hone wheel dresser, eye shields, hex wrench and instruction manual (easy to read/well illustrated) and instructional video.

MODEL A-1 (110V, 60 Cy., 1 Ph.)

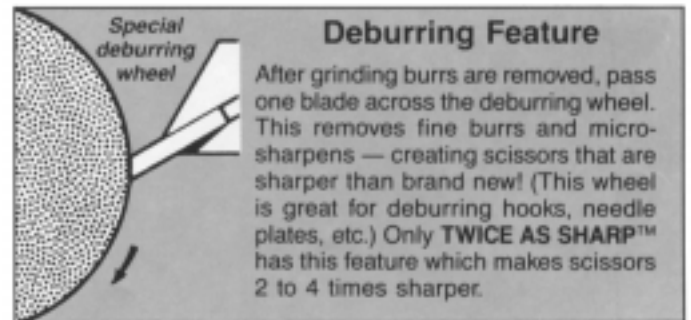
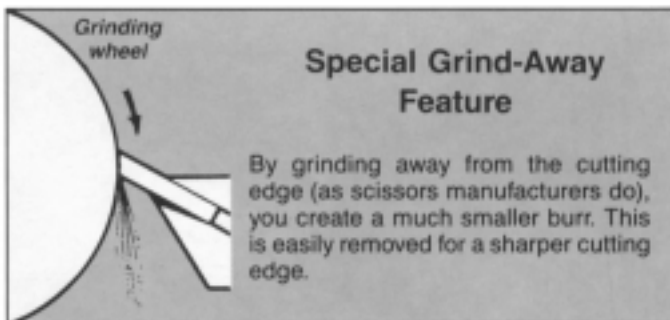
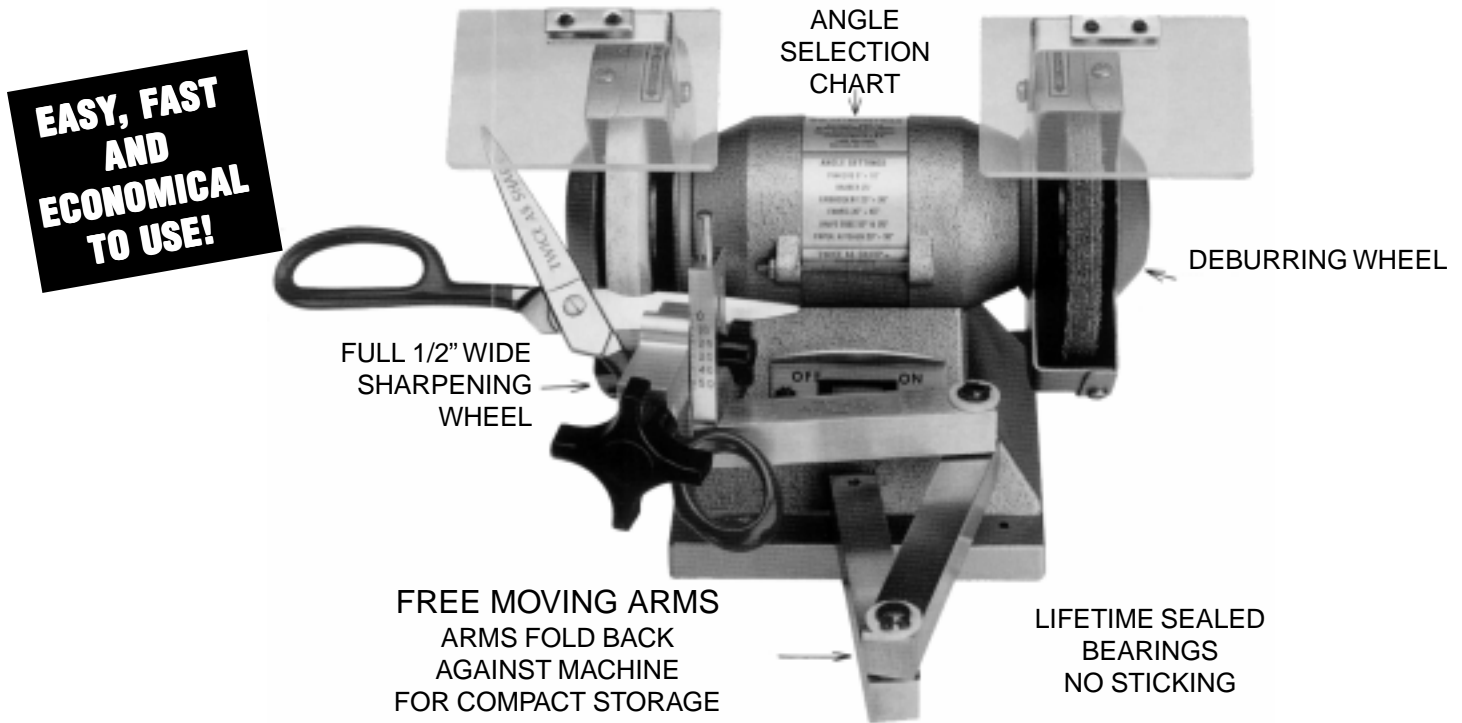

Diamond Needle Corp.

GPO BOX 1355 • 159 W 25 St. • New York, NY 10001
 Phone: (212) 929-2277 • (800) 221-5818
 FAX: (212) 242-8882 • (800) 833-3363





GOLD SEAL



Since 1927 GOLD SEAL has been filling the need for fine industrial cutting instruments. Scissors and shears are designed, engineered and manufactured in the USA to satisfy the demand for continuous use. GOLD SEAL patented and introduced the "Ball Bearing" thread nipper which has become the recognized standard of the industry. GOLD SEAL also introduced the "Knife Edge" grind for shears, scissors and thread nippers.

All GOLD SEAL shears, scissors and thread nippers are made of special high carbon steel, hot drop-forged and then hardened and tempered to exact specifications for outstanding durability and edge retention. After assembly, each pair is individually adjusted and subjected to demanding tests for cutting abilities.

BALL BEARING NIPPERS

Gold Seal "precision" made thread nippers are used in many industrial applications. They are fast, efficient and convenient for any light cutting operation. The nipper fits the hand comfortably leaving fingers free to handle the material.

"Ball Bearing" construction for smoother, easier operation and increases the life of the nipper.

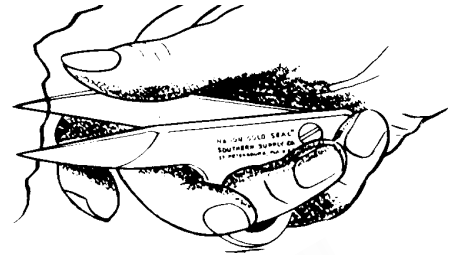

Thread Nippers are "worn" in hand leaving fingers free to handle material.

STANDARD SIZE



ITEM NO.	FINISH	FULL LENGTH	CUT LENGTH
104N	Nickel	4 1/2" - 114mm	1 1/4" - 32mm
104SC	Satin chrome	4 1/2" - 114mm	1 1/4" - 32mm
104BC	Bright chrome	4 1/2" - 114mm	1 1/4" - 32mm
104NKE	Nickel/Knife edge	4 1/2" - 114mm	1 1/4" - 32mm
104SCKE	Satin chrome/Knife edge	4 1/2" - 114mm	1 1/4" - 32mm
104BCKE	Bright chrome/Knife edge	4 1/2" - 114mm	1 1/4" - 32mm
104SCPB	Satin chrome/Blunt points/Knife edge	4 1/2" - 114mm	1 1/4" - 32mm
104NCB	Nickel/Curved blades	4 1/2" - 114mm	1 1/4" - 32mm
104SS	Stainless steel	4 1/2" - 114mm	1 1/4" - 32mm
104SSKE	Stainless steel/Knife edge	4 1/2" - 114mm	1 1/4" - 32mm

KING SIZE



ITEM NO.	FINISH	FULL LENGTH	CUT LENGTH
104LN	Nickel	5" - 127mm	2" - 51mm
104LNKE	Nickel/Knife edge	5" - 127mm	2" - 51mm
104LSCP	Satin chrome/Blunt points	5" - 127mm	2" - 51mm
104LSCBKKE	Satin chrome/Blunt points/Knife edge	5" - 127mm	2" - 51mm

Diamond Needle Corp.

GPO BOX 1355 • 159 W 25 St. • New York, NY 10001
Phone: (212) 929-2277 • (800) 221-5818
FAX: (212) 242-8882 • (800) 833-3363



NOT RESPONSIBLE FOR TYPOGRAPHICAL ERRORS.

POLYMER COATED

Constructed with special blue polymer coating having unique properties and advantages:

- Tough polymer coating will not react to acids and salt in skin.
- Very low coefficient of friction, thread and debris slides off nipper more readily and improves ride.
- Superior corrosion resistance - will not migrate under coating.
- Eliminates contact allergies - prevents dermatitis.
- High visibility color - easy to locate.

NEW!



ITEM NO.	DESCRIPTION	FULL LENGTH	CUT LENGTH
104X	Polymer	4 1/2" - 114mm	1 1/4" - 32mm
104XKE	Polymer/Knife edge	4 1/2" - 114mm	1 1/4" - 32mm

NIPPER HARDWARE (replacement parts)

Note: each part, as indicated in diagram can be ordered individually, by part number.

ITEM NO.	DESCRIPTION
104N10	Main bolt
104N15	Stop screw
104N20	Main spring
104N25	Coil spring for stainless ball
104N30	Fiber insert locknut
104N35	Stainless ball
104N40	Ball bearing in retainer

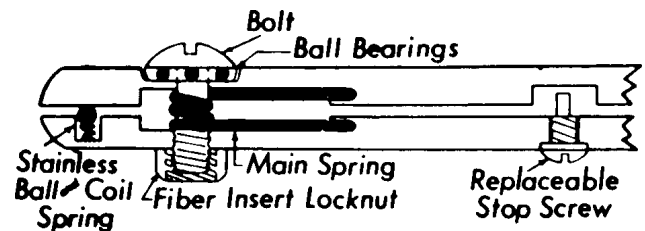

HONES - GOLD SEAL

Ceramic hones produce the finest edge on knife edge shears. A few passes on the cutting edge will restore the edge and eliminate more costly resharpening services.

ITEM NO.	DESCRIPTION	FULL LENGTH
99N (Brown)	Triangular	6" x 1/2" sides
100N (White)	Triangular	6" x 1/2" sides
101N (Brown)	Round w/handle	12" x 5/16" diameter



HEAVY DUTY BENT TRIMMERS - KNIFE EDGE

Rugged, overbuilt for the heaviest service. Used by tailors, carpeters, upholsters, shoe-makers, etc.

- Hot drop-forged, satin chromed, black handles.
- Oversized finger bow for comfort
- Thicker, heavier blades

ITEM NO.	FULL LENGTH	CUT LENGTH
172KE10	10" - 254mm	4 3/4" - 121mm
172LHKE10 (LEFT HAND)	10" - 254mm	4 3/4" - 121mm
180KE12	12" - 305mm	6" - 152mm



BENT TRIMMER - KNIFE EDGE

Professional, dressmaker shears for cutting fabric of all weights and multiple layers. Bent pattern facilitates cutting material on flat surfaces.

- Hot drop-forged, fully satin chromed over nickel, rust/stain resistant.

ITEM NO	FULL LENGTH	CUT LENGTH
171KE6	6" - 152mm	2 5/8" - 67mm
171KE7	7" - 178mm	3 1/4" - 83mm
171LHKE7 1/2 (LEFT HAND)	7 1/2" - 191mm	3 5/8" - 92mm
171KE8	8" - 203mm	3 7/8" - 98mm
171LHKE8 (LEFT HAND)	8" - 203mm	4" - 102mm
171KE9	9" - 229mm	4 3/8" - 111mm
171KE10	10" - 254mm	4 3/4" - 121mm
171KE12	12" - 305mm	5 1/2" - 130mm



STRAIGHT TRIMMERS - KNIFE EDGE

General purpose shears, for industrial, household, utility or any sewing application where bent trimmers are not practicable.

- Hot drop-forged, fully satin chromed over nickel, rust/stain resistant.

ITEM NO	FULL LENGTH.	CUT LENGTH
170KE6	6" - 152mm	2 3/4" - 70mm
170KE7	7" - 178mm	3 1/4" - 83mm
170KE8	8" - 203mm	3 7/8" - 98mm
170KE9	9" - 229mm	4 3/8" - 111mm
170KE10	10" - 254mm	5 3/8" - 137mm



POULTRY SHEARS - KNIFE EDGE

Rounded, blunt points, run smoothly, cut cleanly and last a long time.

- Hot drop-forged cutlery steel that is fully hardened and tempered.
- Fully satin chromed over nickel, rust/stain resistant, will not peel
- Bolt pivot with locking nut - adjustable.

ITEM NO	FULL LENGTH.	CUT LENGTH
190P8 (High Leverage)	8" - 203mm	2 1/4" - 57mm
191P9	8" - 203mm	3 1/4" - 83mm
170PKE9 (Sharp Points)	9" - 229mm	3 7/8" - 98mm



HEAVY DUTY UTILITY TRIMMERS - KNIFE EDGE

Longer handles, heavier construction provide extra leverage and strength for tough cutting tasks. These well balanced shears are ideal for multiple applications, i.e., carpet, garment, food processing, upholstery, leather, etc.

- Hot drop-forged, fully satin chromed over nickel, rust/stain resistant.

ITEM NO.	FULL LENGTH	CUT LENGTH
176KE8	8" - 203mm	3" - 76mm
186KE8 (Larger Finger Bow)	8" - 203mm	3" - 76mm



RUG/UTILITY SHEARS - KNIFE EDGE

Specially designed shears with longer handles and elongated shank that provides extra leverage. These patterns are suitable for close work and tight places. They have wide applications in industries such as: carpet, garment, food processing, upholstery, shoe, and leather goods, etc.

ITEM NO.	FULL LENGTH	CUT LENGTH
179CHKE7 1/2 (Lighter Pattern)	7 1/2" - 191mm	2 3/4" - 70mm
176CHKE8 (Offset Handle)	8" - 203mm	3" - 76mm
170PCB8 (Curved Blades)	8" - 203mm	3" - 76mm
170LHPCB7 (Left Hand)	7 1/2" - 191mm	2 3/4" - 70mm



179CHKE7 1/2



170PCB8

BIG SIX TRIMMER

Tailor point scissors, but with a regular handle.

- Large bows, double sharp points.

178KE6 1/2	6 1/2" - 165mm	2 1/2" - 64mm
-------------------	----------------	---------------



UTILITY SCISSORS

Longer shank, ring handle, very fine sharp points and tapered blades.

- Hot drop-forged, fully nickel plated.
- Increased leverage.

ITEM NO.	FULL LENGTH	CUT LENGTH
157KE5	5" - 127mm	1 5/8" - 41mm



EMBROIDERY SCISSORS - KNIFE EDGE

Double sharp points and tapered blades, designed for light work requiring close detail.

ITEM NO.	FULL LENGTH	CUT LENGTH
154KE4	4" - 102mm	1 1/2" - 38mm
154KE5	5" - 127mm	2 1/8" - 54mm



The BELMONT Alternative...

Belmont scissors and shears are manufactured with the same high standards and methods employed by the leading brands. They are designed to perform their specific tasks with excellence.

With an eye on the future Belmont continues to seek production economies and efficiencies that will insure exceptional values. We source the best available products from all over the country, even around the world. We carry the widest variety to fit almost every cutting application and give you more for your money.

Belmont continues to carry styles and patterns that have been discontinued by the big name manufacturers.

EXTRA LARGE BENT TRIMMERS - ITALY

Finest quality forged steel, precision ground, thru-tempered and hardened to insure excellent performance. Constructed with large contoured comfort handle with a thumb rest for ease of cutting on flat surfaces.

- Hot drop-forged, nickel plated with black handle.
- **Nobody makes them bigger.**
- Self-adjusting pivot with **rest stand**.

ITEM NO.	FULL LENGTH	CUT LENGTH
249/13	13" - 330mm	6 1/4" - 159mm
249/14	14" - 356mm	6 7/8" - 175mm



HEAVY DUTY BENT TRIMMERS - USA

Fine quality and durable shears that are primarily used by tailors, upholsterers auto/marine, and textile cutting applications.

- Hot drop-forged, nickel plated with black handle.
- Adjustable bolt/nut pivot assembly.

ITEM NO.	FULL LENGTH	CUT LENGTH
580/10	10" - 254mm	4 3/4" - 121mm
580/12	12" - 305mm	6" - 152mm



BENT TRIMMERS - USA

The preferred shears for continuous use. These USA manufactured shears are designed for cutting on flat surfaces. Widely used in the textile trade for cutting multiple layers and also for trimming applications.

- Hot drop-forged, nickel plated with black handle.
- Adjustable bolt/nut pivot assembly.

ITEM NO.	FULL LENGTH	CUT LENGTH
571/6	6" - 152mm	2 5/8" - 67mm
571/7	7" - 178mm	3 1/4" - 83mm
571/7 1/2LH (Left Hand)	7 1/2" - 191mm	3 5/8" - 92mm
571/8	8" - 203mm	3 7/8" - 98mm
571/9	9" - 229mm	4 3/8" - 111mm



PATTERN & DESIGNER SHEARS - USA

Heavy duty, easy to use. Constructed with high quality carbon steel, extra long shank and heavy blades. Provides superior leverage for cutting pattern board and other tough materials.

- Hot drop-forged, nickel plated with black handle.
- Knife edge for ease in cutting.
- Blade bottom beveled for controlled cutting.
- Adjustable bolt/nut pivot assembly.



<u>ITEM NO.</u>	<u>FULL LENGTH</u>	<u>CUT LENGTH</u>
8TU	12" - 305mm	3" - 76mm

INDUSTRIAL UTILITY SHEARS - USA

Specially designed shears with **elongated** shank for maximum cutting leverage. Extra leverage is also provided by the increased relative length, shape and handle size. Used extensively in upholstery, auto/marine, poultry processing, florist and any other difficult cutting task.

STANDARD UTILITY SHEARS - USA

Quality high carbon forged steel with **elongated shank** and **regular handle**.

- Hot drop-forged, nickel plated with black handle.
- Adjustable bolt/nut pivot assembly.

<u>ITEM NO.</u>	<u>FULL LENGTH</u>	<u>CUT LENGTH</u>
576/8	8" - 216mm	3" - 76mm



ERGONOMIC UTILITY SHEARS - USA

Quality **high carbon forged steel** similar to item 576/8 but with **longer and larger finger bow**. Enough finger space so that gloves can be worn. Recommended for the very tough jobs.

- Hot drop-forged, full satin chrome over nickel.
- Adjustable bolt/nut pivot assembly.

<u>ITEM NO.</u>	<u>FULL LENGTH</u>	<u>CUT LENGTH</u>
576E/9	8 3/4" - 222mm	3" - 76mm



ERGONOMIC STAINLESS UTILITY SHEARS - USA

Cutlery grade quality stainless steel construction with **elongated shank** for extra leverage. **Ice Tempered**, a special tempering process that doubles cutting edge life.

- Ice tempered, stainless, commercial finish.
- Adjustable bolt/nut pivot assembly.

ITEM NO.	FULL LENGTH	CUT LENGTH
8.5HL	8" - 216mm	3" - 76mm



ERGONOMIX STAINLESS CURVED HANDLE UTILITY SHEARS - USA

Cutlery grade quality stainless steel constructed with **elongated shank** and a **curved handle** for extra leverage and reduced hand fatigue. **Ice Tempered**, to double cutting edge life.

- Ice tempered, stainless, commercial finish.
- Adjustable bolt/nut pivot assembly.

ITEM NO.	FULL LENGTH	CUT LENGTH
502HU	8" - 216mm	3" - 76mm



ERGONOMIC CURVED HANDLE UTILITY SHEARS - USA

Quality high carbon forged steel, same as item 576E/9 but with **longer and larger finger bow**, plus a **curved handle**. This combination produces extra high leverage, reduces hand fatigue and has plenty of finger room.

- Hot drop-forged, full satin chrome over nickel.
- Adjustable bolt/nut pivot assembly.

ITEM NO.	FULL LENGTH	CUT LENGTH
576HU	8 3/4" - 222mm	3" - 76mm



STANDARD UTILITY - RUG SHEARS - USA

Quality high carbon forged steel, heavy duty shears with **offset handle** for trimming pile and cutting in tough, hard to reach places.

- Hot drop-forged, nickel plated with black handle.
- Adjustable bolt/nut pivot assembly.

ITEM NO.	FULL LENGTH	CUT LENGTH
576/CH8	8" - 216mm	2 7/8" - 73mm



SPECIALTY SCISSORS & SNIPS

OFFSET ANGLE EMBROIDERY SCISSORS

Specially designed for close detail trimming work. Also ideal for making cuts under presser feet and other tight places.

- Hot drop-forged, fully chrome plated.
- Double sharp points, ring handle.

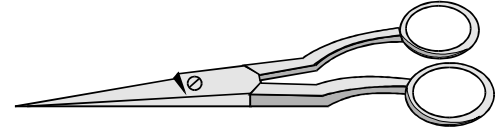

<u>ITEM NO.</u>	<u>FULL LENGTH</u>	<u>CUT LENGTH</u>
584/6 (Italy)	6" - 152mm	1 3/4" - 44mm

CURVED BLADE APPLIQUE SCISSORS

Finely tapered **curved blades** with extra sharp points. Ideal for intricate and detailed work.

- Hot drop forged, fully nickel plated, ring handle.

<u>ITEM NO.</u>	<u>FULL LENGTH</u>	<u>CUT LENGTH</u>
290/4I (Italy)	4" - 102mm	2" - 51mm
290/5I (Italy)	5" - 127mm	2 1/8" - 54mm
290/5 (USA)	5" - 127mm	2 1/8" - 54mm



LARGE RING VERSION

390/4 (Italy)	4" - 102mm	2" - 51mm
----------------------	------------	-----------



LOW PRICE!

All steel, **disposable** (Resharpen or throw-away)

<u>ITEM NO.</u>	<u>FULL LENGTH</u>	<u>CUT LENGTH</u>
290/4P (Pakistan)	4" - 102mm	2" - 51mm
290/5P (Pakistan)	5" - 127mm	2 1/8" - 54mm

SPECIALTY APPLIQUE SCISSORS/PERSONAL GROOMING

Finely tapered **curved blades** for detailed trimming and embroidery work.

- Hot drop-forged, fully chromed, ring handle.

<u>ITEM NO.</u>	<u>FULL LENGTH</u>	<u>CUT LENGTH</u>
696/3 1/2 (Italy)	3 1/2" - 89mm	1" - 25mm

SPECIALTY EMBROIDERY SCISSORS

Finely tapered **short narrow curved blades** for intricate work.

<u>ITEM NO.</u>	<u>FULL LENGTH</u>	<u>CUT LENGTH</u>
634/3 1/2 (Fine) Italy	3 1/2" - 89mm	3/4" - 19mm
628/3 1/2 (Extra fine) Italy	3 1/2" - 89mm	5/8" - 16mm



EMBROIDERY SCISSORS

Double sharp points and finely tapered blades make these scissors ideal for intricate detail work.

<u>ITEM NO.</u>	<u>FULL LENGTH</u>	<u>CUT LENGTH</u>
735/5I (Italy)	5" - 127mm	2" - 51mm

LOW PRICE!

All steel **disposable** (resharpen or throw-away)

<u>ITEM NO.</u>	<u>FULL LENGTH</u>	<u>CUT LENGTH</u>
735/5P (Pakistan)	5" - 127mm	2" - 51mm



STORK EMBROIDERY SCISSORS

Double sharp points and finely tapered blades for intricate work. Delicate enough to cut a baby's nails... able to trim the finest threads.

- Hot drop-forged, gold plated with chrome blades, ring handle.

<u>ITEM NO.</u>	<u>FULL LENGTH</u>	<u>CUT LENGTH</u>
555G	3 1/2" - 89mm	7/8" - 22mm



SAFETY POCKET SCISSORS

Handy, durable enough for many cutting jobs. Just throw 'em in your pocket.

- Hot drop-forged, fully nickel plated, ring handle.
- Double blunt safety points.

<u>ITEM NO.</u>	<u>FULL LENGTH</u>	<u>CUT LENGTH</u>
360/5	5" - 127mm	2 1/8" - 54mm



ELECTRICIAN'S/UTILITY SCISSORS

Quality forged steel construction. Handy tool for cutting insulation, electrical wire, harness ties, etc.

- Hot drop-forged, full commercial finish.
- Double sharp points, ring handle.

<u>ITEM NO.</u>	<u>FULL LENGTH</u>	<u>CUT LENGTH</u>
575E	5" - 127mm	1 3/4" - 44mm



MULTI-PURPOSE SHEARS

Specially designed shears that will cut almost anything, even a penny. Fully stainless steel with plastic handle. A serrated bottom blade and a unique bent handle.

ITEM NO.	FULL LENGTH	CUT LENGTH
420/7	7 3/8" - 187mm	1 5/8" - 41mm



THREAD NIPPERS

STAINLESS STEEL THREAD CLIP - USA

Computer engineered "ICE TEMPERED" stainless steel, self-opening spring action, delrin washer at pivot, 50 % lighter than all steel.

ITEM NO.	FULL LENGTH	CUT LENGTH
415N	4 1/2" - 118mm	1 1/4" - 32mm



DELUXE ECONOMY THREAD CLIP

Lightweight, sharp with replaceable steel blades.

ITEM NO.	FULL LENGTH	CUT LENGTH
TC200	4 3/4" - 121mm	1 1/4" - 32mm



TC201 REPAIR KIT

Contents one (1) pair of blades, four (4) blade screws and one (1) spring

DISPOSABLE ECONOMY THREAD CLIP

Lightweight with sharp steel blades.

ITEM NO.	FULL LENGTH	CUT LENGTH
TC100	4" - 102mm	1 1/4" - 32mm

Stainless, pressed steel, sharp points.

ITEM NO.	FULL LENGTH	CUT LENGTH
TC105	4 1/4" - 121mm	1 1/8" - 29mm



Fiskars has a tradition of quality that dates back to 1649 when they began manufacturing in the village of Fiskars near Helsinki, Finland.

In 1960 Fiskars revolutionized the scissors and shears industry. After years of intensive research and testing, Fiskars introduced lightweight, orange handled scissors with stainless steel blades that were efficient, long-lasting molded handles conformed to the contour of the hand.

Today, Fiskars continues with the same high standards in improving comfort and performance, with innovative, ergonomic and superior quality products.

SOFTOUCH SCISSORS & SHEARS - ERGONOMIC

Oversized cushion grip handle, easy action spring gently opens blades after each cut and reduces fatigue. Contains an adjustable screw for blade tension modification.

- Oversized cushion grip handle.
- Easy-slide lock keeps blades closed
- Ambidextrous



<u>ITEM NO.</u>	<u>FULL LENGTH</u>	<u>CUT LENGTH</u>
F9911	10" - 254mm	3 1/8" - 79mm
F9921	5" - 127mm	1 5/8" - 41mm

STAINLESS BENT TRIMMERS

FISKARS/ORANGE HANDLE

Most popular multi-purpose shears. Great for cutting practically anything from paper to poultry. Easy cutting on flat surfaces.

- Adjustable stainless screw pivot.
- Precision blade alignment.
- Ergonomically designed fiberglass handle.

<u>ITEM NO.</u>	<u>FULL LENGTH</u>	<u>CUT</u>
F9451-8	8" - 203mm	3 7/8" - 98mm
F9450-8LH	8" - 203mm	3 7/8" - 98mm
F9441-9	9" - 229mm	4 1/8" - 105mm



FISKARS/DURA-SHARP

Stainless steel blades are precision ground to maintain their edge. Molded handles for a firm, comfortable grip. This 8" bent trimmer can be used for an unlimited number of tasks. **For left or right handed use.**

- Adjustable rivets allow you to adjust the tension.

<u>ITEM NO.</u>	<u>FULL LENGTH</u>	<u>CUT LENGTH</u>
F1000-8	8" - 203mm	3 1/2" - 89mm



SOFTGRIP & EXECUTIVE SHEARS

New! Midsize multi-purpose shears featuring a soft, long-wearing cushion material bonded to the handle for increased comfort and a sure grip.

- Ambidextrous.
- Adjustable screw pivot.

ITEM NO.	FULL LENGTH	CUT LENGTH
F9880-8	8" - 203mm	3 7/8" - 98mm



PINKING SHEARS

For finishing the edges and seams of cloth and other material.

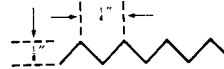

ITEM NO.	FULL LENGTH	CUT LENGTH
F9445-9	9" - 229mm	3" - 76mm



SHORTCUT SNIPS

Great for snipping and trimming. Left or right handed.

ITEM NO.	FULL LENGTH	CUT LENGTH
F9495	5" - 127mm	1" - 25mm



SPECIALTY ROTARY/UTILITY CUTTER

Razor sharp, cut nearly effortlessly through multi-layers of fabric. Cutter accepts 10 styles of blades that mount on either side for left or right handed use.

- Contoured handle for comfort.
- Convenient loop handle for sure grip.
- Easy to access blade lever and release button.

ITEM NO.	BLADE SIZE	BLADE STYLE
F9521	45mm	Straight



ROTARY BLADES

ITEM NO.	BLADE SIZE	BLADE STYLE
F9531	45mm	Straight
F9539	45mm	Scallop

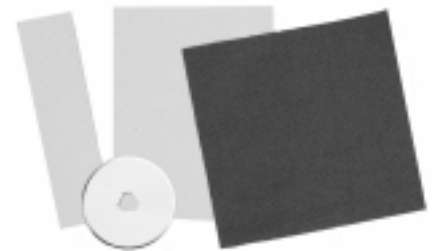

SELF-HEALING CUTTING MATS

Two-color grid mats are reversible with durable three-layer construction. Surface layers are self-healing and tough inner layer resists penetration.

ITEM NO.	MAT SIZE (IN")	MAT SIZE (METRIC)
F8621	18" X 24"	457mm X 610mm
F8631	24" X 36"	610mm X 914mm





STAINLESS STEEL MESH SAFETY GLOVES

Chainex metal mesh safety gloves are manufactured in compliance with the major international safety standards - **UL, CSA, EC,GS**. Chainex gloves provide a great measure of safety for many jobs with meat, fish, textiles, leather, cardboard, plastic and metal. The gloves offer a high level of protection against cuts and stab wounds with maximum comfort for flexible hand movement.

- Lightweight, AISI 316 stainless steel links.
- Adjustable nylon straps with snap fasteners.
- Complies with USDA requirements.
- Three (3) and Five (5) finger styles.
- Five (5) finger glove is reversible/ambidextrous.
- Instructions, maintenance, cleaning/storage information included.

CHAINEX GLOVE CHAINMAIL
 Stainless steel AISI 316L
 Welded rings
 External diameter of the rings: 4mm
 Wire diameter: 0.5mm

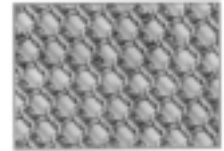

THREE FINGER GLOVES

ITEM NO. DESCRIPTION

MG300XS Extra Small - Left
MG300XSA Extra Small - Right

MG300S Small - Left
MG300SA Small - Right

MG300M Medium - Left
MG300MA Medium - Right

MG300L Large - Left
MG300LA Large - Right

MG300XL Extra Large - Left
MG300XLA Extra Large - Right



FIVE FINGER GLOVES

ITEM NO DESCRIPTION

MG500XS Extra Small

MG500S Small

MG500M Medium

MG500L Large

MG500XL Extra Large

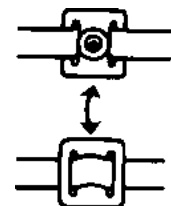

Reversible five finger gloves, as indicated by pictogram, easily switched from left to right hand by simply turning the glove and fastener inside out.

ULTRA-LAMEX/CHAINEX APRONS

ULTRA-LAMEX aprons, made of aluminum plates, are strong and flexible. **CHAINEX** chainmail is tough and very comfortable.

Both types of aprons provide safety for the upper part of the body and are designed not to hamper movement. The aprons are fitted with a belt and wide adjustable, detachable straps, specially designed to prevent fatigue.

- Rectangular aluminum plates (35X19mm)
- Stainless steel rings, AISI 316L
- Chainmail made from welded rings, stainless steel AISI 316L wire thickness is 0.8mm with internal diameter of 5.5mm.













ULTRA-LAMEX APRONS

ITEM NO.	DESCRIPTION
UL24X22	24"X22" For persons under 5'5"
UL30X22	30"X22" For persons over 5'5"

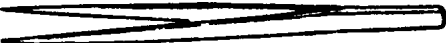
CHAINEX APRONS

ITEM NO	DESCRIPTION.
CH24X22	24"X22" For person under 5'5"
CH30X22	30"X22" For persons over 5'5"

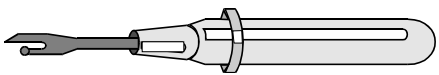
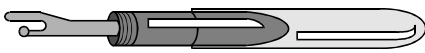
ASSORTED HELPFUL TOOLS

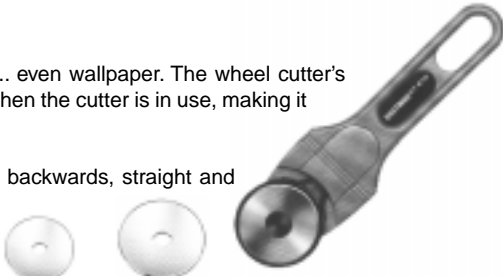
<p>SELF-LOCKING TWEEZER #TWE15 (4-1/2") #TWE16 (6-3/4")</p>  <p>Stainless steel.</p>	<p>STRAIGHT 4" TWEEZER W/HOOK #TWE3</p>  <p>Stainless steel Ribbed points, hook at end</p>	<p>DELUXE 5" BENT TWEEZER #TWE4</p>  <p>Precision points, stainless steel.</p>
<p>DELUXE 6" BENT TWEEZER #TWE6</p>  <p>Has alignment pin. Precision points, Picks up the finest threads.</p>	<p>STAINLESS 6" TWEEZER #TWE7</p>  <p>Bent tweezer Precision points Forged stainless steel</p>	<p>STRAIGHT 6" TWEEZER #TWE8</p>  <p>Stainless steel Precision points, pinpoint accuracy</p>
<p>SCISSOR TYPE 6" CLAMPING PLIERS #EW166</p>  <p>Stainless steel.</p>	<p>HANDY AWL #HA3</p>  <p>Hardened point Hardwood handle Used for marking dots in pattern paper</p>	<p>BRASS TIPPED 60" FIBERGLASS TAPE MEASURE #242TM</p>  <p>Inches on one side - brass tip w/hole Metric on the other - alternate direction</p>
<p>SMALL SEAM RIPPER (3-1/2" overall length) #110R</p>  <p>Safety ball Hexagonal rib prevents rolling</p>	<p>LARGE SEAM RIPPER (5-1/2" overall length) #111R</p>  <p>Safety ball Sure grip handle Clear plastic ribbed cover</p>	<p>FLAT PATTERN SEAM RIPPER (5" overall length) #112R</p>  <p>Flat handle Safety ball Clear plastic cover Simulated wood handle</p>
<p>WHEEL CUTTER AS VERSATILE AS IT IS SAFE</p> <p>It cuts patterns, fabrics, leather, vinyl, mylar.... even wallpaper. The wheel cutter's unique permanent blade guard retracts only when the cutter is in use, making it one of the safest tools in the cutting room.</p> <p>Both left and right handed. Cuts forward and backwards, straight and curves.</p> <p>Easily replaceable tungsten steel blades</p> 		<p>No. EW810 - Complete unit No. EW801 - replacement blade 1-3/4" (4.5cm)</p> <p>No. EW800 - Complete unit No. EW811 - replacement blade 1-1/16" (2.7cm)</p>

Diamond Needle Corp.

GPO BOX 1355 • 159 W 25 St. • New York, NY 10001
Phone: (212) 929-2277 • (800) 221-5818
FAX: (212) 242-8882 • (800) 833-3363



**WHITE
DIAMOND**

DIXON INDUSTRIAL CRAYONS & MARKERS

DIXON TAILOR'S CRAYONS

Finest quality, compressed for long wearing, non-crumbling use. Withstands pressing. 2" square flat shaped double beveled.



- D901 RED
- D902 BLUE
- D903 WHITE
- D903-1/2 YELLOW

PACKED 2 DOZEN PER BOX (Sold in multiples of 2 dozen)

DIXON CLOTH MARKER TEXTILE PENCILS

Semi-permanent formulation will not wash out or bleach out in most processes. Test carefully if bleach out is required. Dixon can assume no liability for fugitivity. Large diameter leads.

- D787B BLUE
- D787R RED
- D787G GREEN



PACKED 1 DOZEN PER BOX (Sold in multiples of 1 dozen)

DIXON WASHOUT TEXTILE PENCILS

Special fugitive formulation designed to water-wash from most natural and synthetic fabrics. Dixon can assume no liability for fugitivity. Large diameter leads.

- D783B BLUE
- D783R RED
- D783G GREEN



PACKED 1 DOZEN PER BOX (Sold in multiples of 1 dozen)

DIXON CHINA MARKING (PHANO)

This improved china marking pencil is one of the most versatile of all marking instruments. The opaque pigment marks all glazed and slick surfaces. Grit free, non-conductive leads. Round paper-wrapped with string for easy sharpening.

- D71 RED
- D73 YELLOW
- D77 BLACK
- D92 WHITE



PACKED 1 DOZEN PER BOX (Sold in multiples of 1 dozen)

DIXON TAILORING PENCILS

- D349 RED D352 WHITE
- D350 BLUE D353 YELLOW

THICK LEADED COLORED PENCILS

**PACKED 1 DOZEN PER BOX
(Sold in multiples of 1 dozen)**



Diamond Needle Corp.

GPO BOX 1355 • 159 W 25 St. • New York, NY 10001
Phone: (212) 929-2277 • (800) 221-5818
FAX: (212) 242-8882 • (800) 833-3363



PHOTOCOPY THIS ORDER FORM

ORDER FORM

MAIL OR FAX TO US!

TO: **DIAMOND NEEDLE CORP.**
159 West 25th Street / G.P.O. Box 1355
New York, NY 10001



**WHITE
DIAMOND**

**WE NOW ACCEPT
VISA, MASTERCARD
and DISCOVER**



CALL OR FAX US TOLL FREE!

TELEPHONE: 1-800-221-5818

FAX: 1-800-833-3363

INTERNATIONAL PHONE: 212-929-2277

INTERNATIONAL FAX: 212-242-8882

BILL TO: _____
ADDRESS: _____
CITY: _____
STATE: _____ ZIP: _____
PHONE: (_____) _____
ORDERED BY: _____

SHIP TO: _____
ADDRESS: _____
CITY: _____
STATE: _____ ZIP: _____
PHONE: (_____) _____
ATTENTION: _____

QUANTITY	ITEM NO.	DESCRIPTION	UNIT PRICE	EXTENSION

SUB-TOTAL	
NYS SALES TAX	
TOTAL	

TERMS & CONDITIONS OF ORDERING

TERMS: (1) Qualified accounts, approved by our credit department, are allowed NET-30 DAYS. (ask for credit application).

SALES TAX: We are only responsible for NYS sales tax.

F.O.B., NEW YORK, NY: All items are sold F.O.B. NY, NY.

METHOD OF SHIPMENT: Unless specified otherwise, we reserve the right to determine the best method of shipment.

MINIMUM ORDERS: In order to help keep our prices low, we have a requirement of a minimum order of \$25.00 excluding freight and sales tax. A service charge of \$5.00 will be added to orders under \$25.00. Avoid any service charge by increasing your order with some item(s) that you'll always need... thank you.

CREDIT CARD INFORMATION

TYPE: VISA MASTERCARD DISCOVER

NAME ON CARD: _____

CARD NO.: _____

EXPIRATION DATE: _____

SIGNATURE: _____

PLEASE NOTE: TO USE ORDER FORM WE SUGGEST THAT YOU MAKE A COPY OF THIS FORM. IF YOU NEED MORE ITEMS THAN THERE IS ROOM FOR... MAKE AN EXTRA COPY FOR THE ADDITIONAL ITEMS. THANK YOU.

ORGAN NEEDLES



We stock thousands of additional items that are not shown in this catalog. If you do not see what you need - call and ask!

OR

You can E-mail us at: Diamond-Needle@worldnet.att.net

A SEWING MACHINE IS ONLY AS GOOD AS THE NEEDLE IN IT!

The Organ Needle Company works closely with all of Japan's sewing machine builders to design and manufacture needles for optimal performance. A machine builder cannot afford to buy an inferior needle at any price!

Next time you order replacement needles for your best machines, order the needles your machine builder uses. When you buy **ORGAN** needles for their outstanding performance you get their *low price* as a bonus.

Would any machine builder jeopardize his reputation by supplying an inferior needle with his machine? How much could he save, .10 or .20 per needle, \$1.00 or \$2.00 per machine? The price of a needle is not a factor to him -- *PERFORMANCE is the factor!* Price is an added benefit, a bonus you always get with every box of **ORGAN** needles.

ORGAN needles are supplied with every new machine from:
BROTHER, JUKI, MITSUBISHI, YAMATO, KANSAI, PEGASUS, CONSEW, TAJIMA, BARUDAN, NAKAJIMA, KINGLINE, NEWLONG, TOYOTA, RENOWN, and many more...

After you've used-up the *free* needles packed with your new machine, which performed flawlessly, WHY change to a more expensive needle? What can you gain? How could any needle at any price be better than those made to the machine builder's specifications? How could a copy, even a more expensive copy, be better than O.E.M. specs?

Diamond Needle Corp.

GPO BOX 1355 • 159 W 25 St. • New York, NY 10001
Phone: (212) 929-2277 • (800) 221-5818
FAX: (212) 242-8882 • (800) 833-3363



DIAMOND NEEDLE CORP.

G.P.O. Box 1355
 159 West 25th Street
 New York, NY 10001
 Phone: (212) 929-2277 • (800) 221-5818
 Fax: (212) 242-8882 • (800) 833-3363

**We're your source...
 DELIVERY QUALITY ECONOMY**

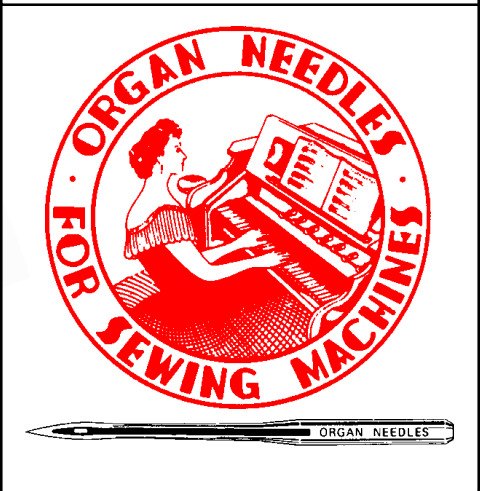
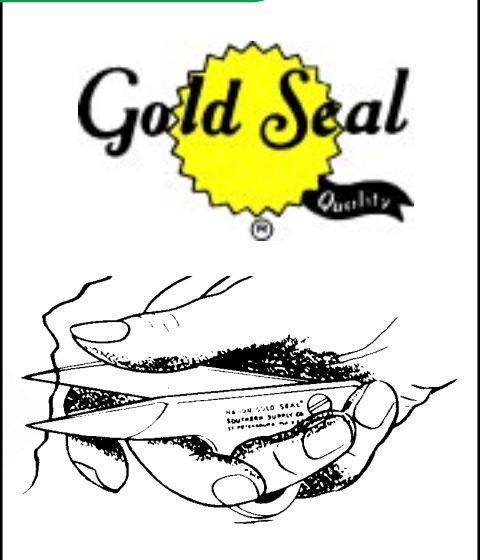

Performance Beyond The Ordinary!

**Diamond
 Needle
 Corp.**



**WHITE
 DIAMOND**

G.P.O. 1355
 159-163 WEST 25TH STREET
 NEW YORK, NY 10001
 E-mail: Diamond-Needle@worldnet.att.net



**212-929-2277
 CALL TOLL-FREE
 1-800-221-5818**



**1-800-833-3363
 (DOMESTIC)
 212-242-8882
 (INTERNATIONAL)**